

FENDER LESS KIT NO.1/2

CODE : 691-0240000

APPLICATION : XSR125 (RE46J) BVF1

● Thank you for purchasing Kitaco product. Read and understand the instruction before installing.

■ ATTENTION (MUST READ)

- This instruction sheet is for the instruction for genuine condition.
- This product is for dress-up. Do not use for other purposes.
- This product is designed and made exclusive for application vehicles, do not use other models. Do not modify the way which is not listed or it will cause damage and trouble.
- We are not responsible for violation of law or damages and accidents caused by assembling mistake and improper setting.
- Refer to the manufacturer service manual when installation.
- Bolts and nuts may get loosen by engine vibration. Make sure not to loosen any bolts and nuts before driving.

PACKING LIST				
Fig	NAME	CODE	QTY	REMARK
1	NUMBER PLATE BASE	691-0240001	1	
2	WINKER SPACER	R 25	691-0770103	2
3	FLANGE HEXAGON BOLT	M6x20	062-0561020	4 TORQUE : 12N · m
4	REFLECTOR (SLIM)	19x98	0900-801-90002	1
5	LED LICENSE LAMP Assy	R 25(15)	691-0770104	1
6	WASHER	3mm	-	2
7	NUT	3mm	-	2
8	PROTECTION CAP (BLACK)	φ 2.5	998-9000201	2

■ HOW TO INSTALL (Refer to the manufacturer service manual.)

- 1) Remove the seat and rear fender cowl (6 screws/ 4 stepped bolts).
- 2) Remove the tail light connector and the connector located on the underside of the seat.
- 3) Remove the rear fender assembly (bracket).
(Remove the factory rear fender while pulling out the indicator and license lamp wires from the bracket from the vehicle side.)

※ Be careful not to damage the nails of the covers when removing and installing the fender assembly.

Continue to Exhibit No. 2

STOCK PARTS

Fig	NAME	QTY	REMARK	Fig	NAME	QTY	REMARK
N1	REAR FENDER COWL/TAIL LAMP	x1	REUSE	N4	STOCK FLANGE NUT	x4	REUSE
N2	REAR FENDER Assy	x1	DISUSE	N5	STOCK COLLAR	x4	REUSE
N3	REAR TUN SIGNAL/LOCK BRACKET (L/R)	EACH 1	REUSE	N6	GROMMET	x1	REUSE

REAR FENDER/REAR BLINKER LIGHT REMOVAL DIAGRAM

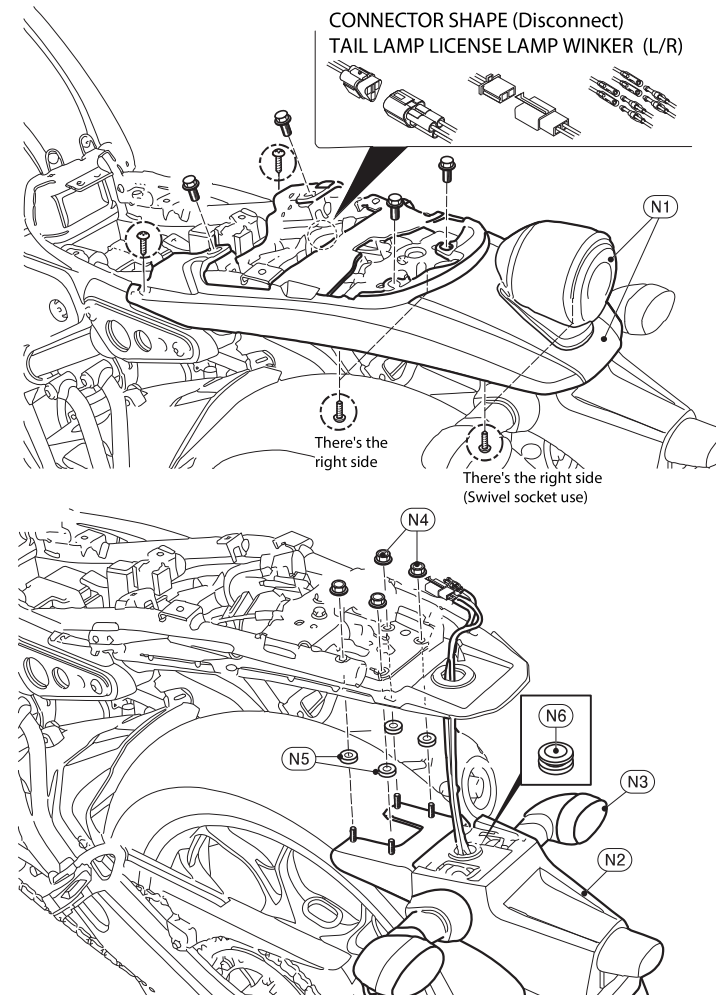

FENDER LESS KIT NO.2/2

CODE : 691-0240000

APPLICATION : XSR125 (RE46J) BVF1

■HOW TO INSTALL (This is just a reference, please refer to the manufacturer service manual.)

- 4) Install the supplied fenderless parts group. (Refer to the figure.) Reuse the stock indicator. After routing and wiring, tie the wiring to the frame with the supplied tie wraps so that it does not hang down.
- 5) Tighten the temporarily tightened bolts. Finally, check that there is no wobble in any part and that all lamps are working properly, and all lamps are working properly before driving.

PACKING LIST

Fig	NAME	CODE	QTY	REMARK
1	BASE PLATE	691-0240001	1	
2	WINKER SPACER	R 25	2	
3	FLANGE HEXAGON BOLT	M6x20	4	TORUQE : 12N · m
4	REFLECTOR (SLIM)	19x98	1	
5	LED LICENSE LAMP Assy	R 25(15)	1	
6	WASER	3mm	2	
7	NUT	3mm	2	
8	PROTECTION CAP (BLACK)	φ 2.5	2	

STOCK PARTS

Fig	NAME	QTY	REMARK	Fig	NAME	QTY	REMARK
N1	REAR FENDER COWL/TAIL LAMP	x1	REUSE	N4	STOCK FLANGE NUT	x4	REUSE
N2	REAR FENDER Assy	x1	DISUSE	N5	STOCK COLLAR	x4	REUSE
N3	REAR TURN SIGNAL/LOCK BRACKET (L/R)	EACH 1	REUSE	N6	GROMMET	x1	REUSE

- ※Parts not included in the kit are basically reused from stock parts.
- ※If parts to be reused have significant deterioration such as scratches, dents, or wear, please replace them with new parts.

BOLT · NUT TORQUE

6mm	10 ~ 12N·m (1.0 ~ 1.2kgf·m)
3mm	1 N·m (0.1kgf·m)

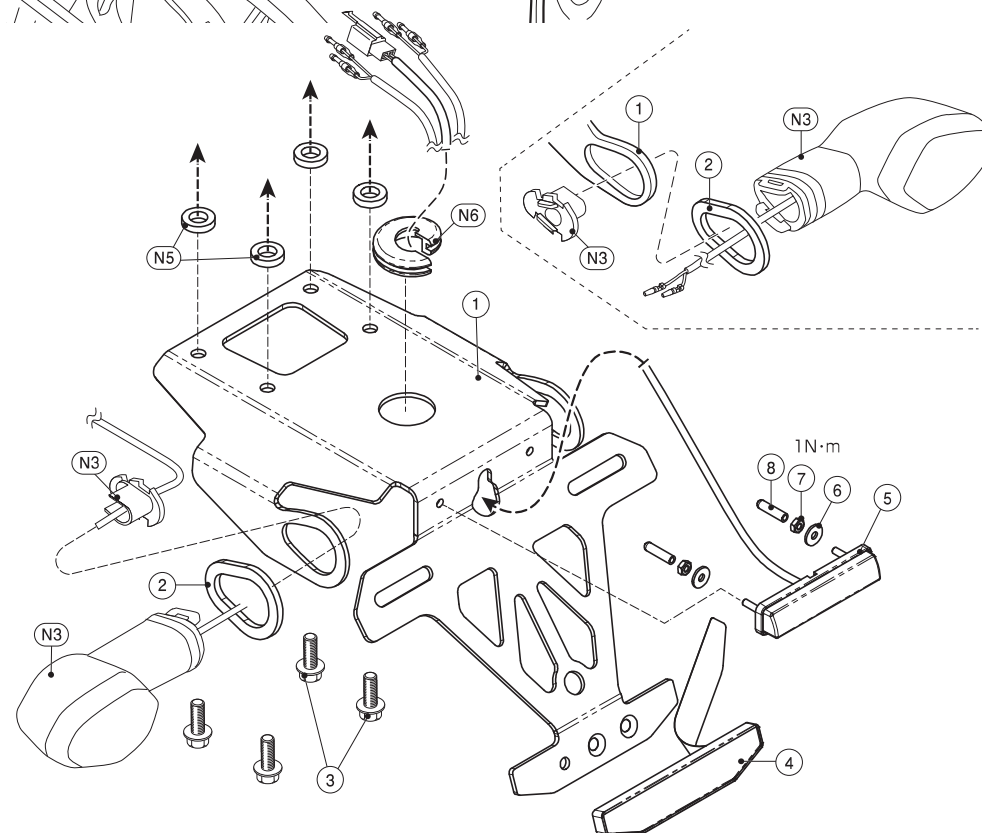
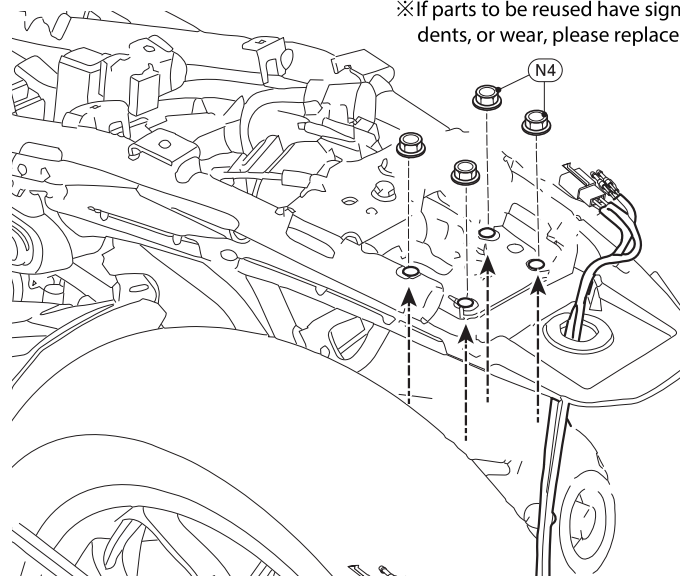

240417 M-T

<https://www.kitaco.co.jp/>