



# 124cc NEW STD BIG BORE KIT

## THE DETAILS THAT COMBINE POWER AND URABILITY!

### NEW STD CYLINDER HEAD

BIG VALVE, HIGH CAMSHAFT, AND HIGHLY EFFICIENT PORT SHARP ACHIEVE POWER AND TORQUE ACROSS WIDE RANGE THAT IS INCOMPARABLE TO STOCK HEAD. **●VALVE ASSEMBLED**

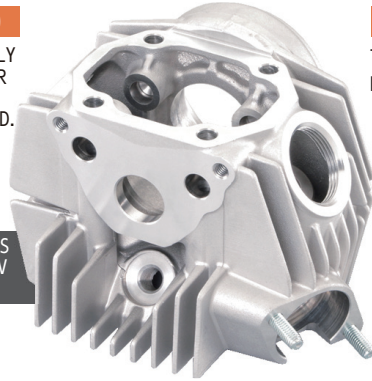

CYLINDER HEAD INSIDE PARTS ARE DESIGNED BASED ON 12V MONKEY.

### COMBUSTION CHAMBER/PORT

THE COMBUSTION CHAMBER HAS BEEN EXPANDED TO  $\phi 52$  TO FURTHER OPTIMIZE COMBUSTION EFFICIENCY. CROSS-FLOW COMBUSTION CHAMBER SHARP SHORTENS DISTANCE.



### STD VALVE

DESIGNED WITH DURABILITY AND COMBUSTION CHAMBER SHAPE AND SIZE IN MIND. LARGE DIAMETER VALVE WITH VALVE FACE DIAMETER OF IN  $\phi 25$  AND EX  $\phi 22$ .

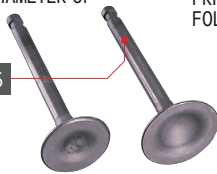

STEM O.D.  $\phi 5.5$

### NEW STD VALVE SPRING

NEW REINFORCED VALVE SPRING EXCLUSIVELY DESIGNED FOR STD CYLINDER HEAD WITH REDUCED FRICTION LOSS AND FOLLOWABILITY.



### HIGH CAM SHAFT

CAMSHAFT WITH BEARING, WHICH HIGHLY WORKS AT HIGH RPM RANGE. 12V STOCK CYLINDER HEAD USABLE.



### REINFORCED CAIN EK25HS

CHAIN PLATE GUARANTEES HIGH STRENGTH, SOLID BUSHING WITH WEAR RESISTANCE AND HIGH PRECISION, AND CHROMIZING TREATMENT (WEAR RESISTANCE, SEIZURE RESISTANCE, CORROSION RESISTANCE, etc.) IS APPLIED TO REDUCE WEIGHT.



### CYLINDER

HARD-PLATED ALUMINUM CYLINDER THAT IS ENTIRELY MADE OF ALUMINUM, HAS EXCELLENT HEAT DISSIPATION, AND IS RESISTANT TO DISTORTION.



### $\phi 54$ PISTON

ALUMINUM CASTING PISTON WITH AN APPROPRIATE COMPRESSION RATIO AND MILD OUTPUT CHARACTERISTICS



COMPRESSION RATIO 10.6 : 1

WPC+MOS2 MODS PISTON FOR HIGH DURABILITY & FRICTION REDUCTION

### 54mm LONG STROKE CRANK SHAFT

SIGNIFICANTLY, IMPROVES THE ABILITY TO WITHSTAND HIGH-OUTPUT ENGINES AND REDUCE FRICTION LOSS.

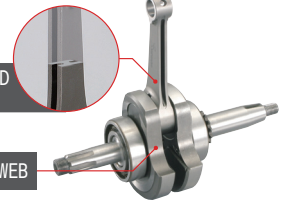

HIGH INTENSITY H-SHAPED CONNECTING ROD

LIGHT WEIGHT CRANK WEB

### 124cc NEW STD BIG BORE KIT RECOMMENDED PARTS

CARBURETOR	MIKUNI VM $\phi 26$ BIG CARBURETOR KIT	▼RECOMMENDED
	KEHIN PWK $\phi 28$ BIG CARBURETOR KIT	▼RECOMMENDED
OIL PUMP	ULTRA OIL PUMP KIT	▼MUST
OIL COOLER	SUPER OIL COOLER KIT	▼RECOMMENDED
CLUTCH	ULTRA CLUTCH KIT	▼MUST
CDI	REVCOM	▼RECOMMENDED
ENGINE OIL	ELF MOTO4 PROTECK	▼MUST

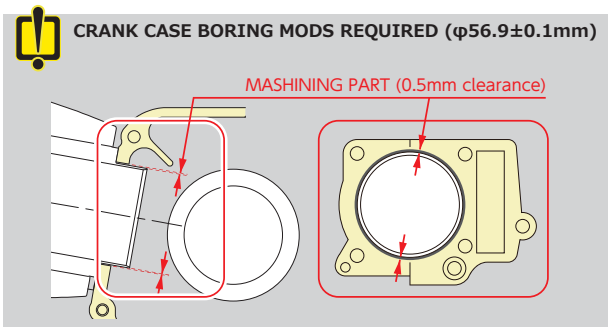

### APPLICATION

MONKEY / GORLLA  
FNo.Z50J-2000001 ~ /  
FNo.AB27-10000001 ~ 1899999  
MONKEY BAJA (ALL)  
XR50R/CRF50F (AE03),  
XR70R/CRF70F (DE02)

### FEATURE

ODISPLACEMENT : 124cc  
BORE :  $\phi 54$   
STROKE : 54mm (LONG STROKE)  
OVALVE ASSEMBLED  
OCYLINDER :  
ALUMINUM HARD PLATED CHROME  
OPISTON :  
ALUMINUM CASTING (WPC + MoS2 mods)  
OCOMPRESSION RATIO : 10.6 : 1

Compared to stock engine, the length of engine will be 6mm forwarded. Please make sure to have there is enough space between engine and tire or front fork, which causes serious injuries or accidents, if they touches when bottomed.

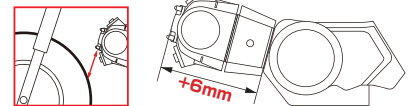

CODE	215-1083117	PRICE	¥ 115,000
------	-------------	-------	-----------