

TANDEM BACK REST

APPLICATION	LEAD125(JF45/JK12) / DIO110(JF31/58/JK03) / sh mode(JF51)	
CODE	(SILVER) 652-1434000	(BLACK) 652-1434200

Thank you for purchasing Kitaco product. Read and understand the instruction before installing.

ATTENTION (MUST READ)

- This instruction sheet is for the instruction for genuine condition.
 - This product is for back rest for tandem riding. Do not apply excessive force to back rest. It might cause of break this product or surrounding parts.
 - This product is designed and made exclusive for application vehicles, do not use other models. Do not modify the way which is not listed or it will cause damage and trouble.
 - We are not responsible for violation of law or damages and accidents caused by assembling mistake and improper setting.
 - Please ask authorized mechanic for assembling and setting.
 - Refer to the manufacturer service manual when installation.
 - Bolts and nuts may get loosen by engine vibration. Make sure not to loosen any bolts and nuts before driving.
- UNEVEN BRIGHTNESS
There might be uneven brightness because of polishing treatment, but it is not defective product.

PACKING LIST

FIGURE	NAME	CODE	QTY	REMARK
1	TANDEM PAD STAY	652-1434000	x1	SILVER(SUS)
	TANDEM PAD STAY	652-1434200	EACH	BLACK
2	FLANGE CAP BOLT (sus) M8 × 25	080-0563025	× 2	
3	PAD 300	652-0500010	× 1	
4	FLANGE LOCK NUT 8mm	001-0550008	× 4	
5	WASHER 8 × 22 × T2.3	090-0902008	× 2	For fixing pad.

HOW TO INSTALL

※ If there is a hard degradation like a blem, fatigue and wear etc on the reuse parts, please change to new ones.

Install this product on rear carrier with attached parts.

※ Illustration carrier is LEAD125. Please install to other models in the same way.

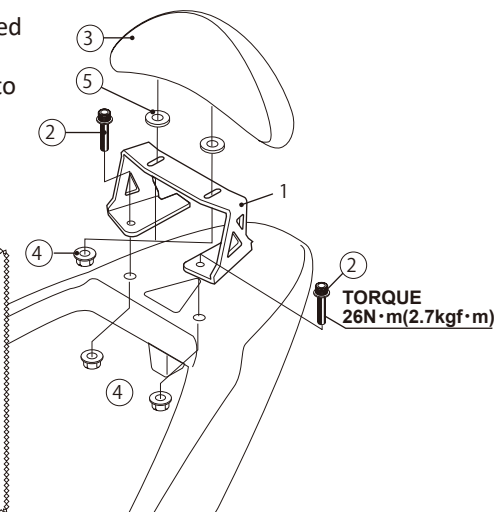

ATTENTION!

- This product cannot have toughness because of the vehicle structure. Do not apply excessive force to carrier and back rest such as using rope or tie to deliver the vehicle. In case of using as back rest, please use as supporting parts.
- Pad part is not perfectly waterproof. Even if the surface is dry, permeated water by rain or wash might effect to passenger. Be careful of it.
- Direct sun light or ages may cause of discolored. Please understand before installation.

220629 Y-N

KITACO
株式会社 キットコ

3-8-13 NAGATA,
HIGASHI-OSAKA,
OSAKA, JAPAN