





## GPR DOWN TYPE MUFFLER (M1 TYPE)

APPLICATION	Dio 110 EBJ- (FNO,JF58-1000001 ~ 1099999) /2BJ- (FNO,JF58-1100001 ~ )
CODE	548-1437310

● Thank you for purchasing Kitaco product. Read and understand the instruction before installing.

### ATTENTION (MUST READ)

- We are not responsible for violation of law or damages and accidents caused by assembling mistake and improper setting.
- This product is designed and made exclusive for application models, do not use other models.
- Please ask authorized mechanic for assembling and setting. Ask a specialist at specialty shop if you do not understand the role of the surrounding parts.
- Refer to the manufacturer service manual when installation.
- Bolts and nuts may get loosen by engine vibration. Make sure not to loosen any bolts and nuts before driving.

	This sheet is intended for the person who has basic knowledge for maintenance. Do not operate if you do not have skill and knowledge.		Do not touch the engine parts (cylinder, crankcase, muffler, engine oil, etc) right after engine operation. Make sure to start the installation after the engine parts are completely cool.		<b>FLAMMABLES</b> Inflammable high gasoline is used during operation.
	Do not modify the way which is not listed or it will cause damage and trouble.		The shape is different from genuine one, please be careful of burning until get used to it.		

PACKING LIST *( ) is 1set qty.			
FIGURE	NAME	CODE	QTY
1	SILENCER ASSY (SUS/GPR)	559-0500000	(× 1)
2	EXHAUST PIPE ASSY	541-1437490	(× 1)
3	SILENCER STAY	541-1437480	(× 1)
4	SILENCER BAND	φ 112	0900-995-10110 × 2
5	SILENCER BAND RUBBER	110/2.5Tmm	0900-999-11110 × 2
6	FLANGE CAP BOLT	M8 × 35	080-0563035 × 2
7	WASHER	8 × 18 × T1.2mm	090-0601082 × 2
8	U NUT	8mm	001-0540008 × 2
9	SPRING (SUS)	8 × 57	542-9998000 (× 2)
10	SPACER COLLAR	18 × 8.2 × T5	0900-093-00014 × 2

OPTION PARTS (SOLD SEPARATELY) *( ) is 1set qty.			
FIGURE	NAME	CODE	QTY
OP1	MUFFLER GASKET (XH-02)	963-1000002	(× 2)
-	LIQUID GASKET (KC-027)	0900-969-00010	× 1

(This instruction sheet is just a reference, please refer to the manufacturer service manual.)

- ※ Basically, reuse genuine parts if it is unattached. If there is a hard degradation like a blem, fatigue and wear etc on the reuse parts, please change to new ones.
- Install Kitaco muffler temporarily with installing attached parts. (Refer to the illustration.)
- ※ Apply liquid gasket (KC-027) that sold separately to connecting point of silencer and exhaust pipe not to leak exhaust. Do not start engine until liquid gasket is dry. (around 1 hour)
- ※ Recommend to change muffler gasket to new one (sold separately).
- Tighten with specified torque while adjusting each parts. Make sure not to leak exhaust.

#### INSTALLING EXHAUST PIPE PART

※ Apply grease to both surface when installing not to slip. (recommend)

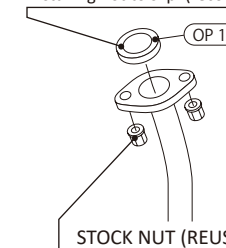

**TORQUE : 20~23N·m**

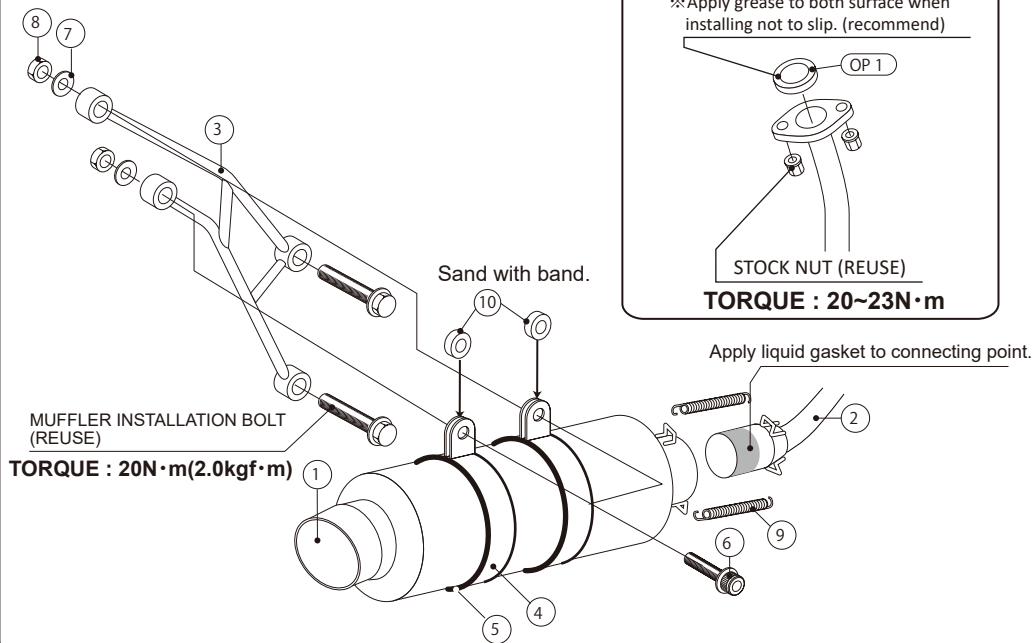

#### ATTENTION!

After riding a lot, surface of the product (especially exhaust pipe) might change its color, but it's not unusual. If you want to remove burning, please use specified chemicals that sold commercially.

- If starting engine with oil or dirt, it changes color or burned (only that place). Please wipe it with degreaser before starting engine.

- Do not leave this product with water. It might cause of tarnish or rust.

#### HOW TO TAKE CARE

● Rust and corrosion caused by surface oxidation is caused by exhaust high heat. Genuine muffler is the same.

This is characteristic, which cannot avoid. However, it only occurs to surface. Applying heat resist silicone wax to delay tarnish.

171013 Y-N



3-8-13 NAGATA,  
HIGASHI-OSAKA,  
OSAKA, JAPAN