



UNDER THE STEERING WHEEL SPOKE OF FOLLOWING MODEL

LEXUS

LBX SERIES · LC500h · LM SERIES · LX600 · NX450h · RX SERIES · RZ SERIES · UX SERIES

TOYOTA

LAND CRUISER (70 · 250 · 300 SERIES) · LAND CRUISER PRADO (150 SERIES) · HILUX (120 SERIES) · HARRIER (80 SERIES) · ALPHARD/VELLFIRE (30 · 40 SERIES) · CROWN SPORTS (30 SERIES) · CROWN CROSSOVER (30 SERIES) · PRIUS (50 · 60 SERIES) · VOXY (90 SERIES) · CH-R (10 SERIES) · RAV4 (50 SERIES) etc.

※ NOT FOR THE MODELS WITH PADDLE SHIFT

PROTECTION GOODS SECURITY item

HANDLE LOCK SHL-02 STANDARD

K · TECT SECURITY LEVEL : **80**

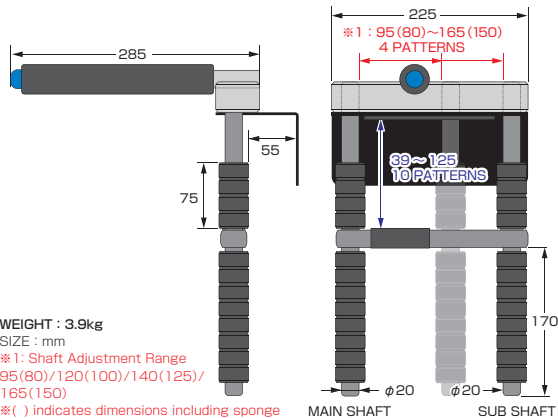
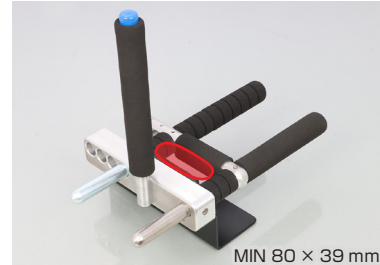

WEIGHT : 3.9kg
SIZE : mm
※ 1 : Shaft Adjustment Range
95 (80) / 120 (100) / 140 (125) /
165 (150)
※ () indicates dimensions including sponge

REMARKS

- UPPER BRACKET : HIGH STRENGTH DURALUMIN / HAIR LINE FINISH
- UNDER BRACKET : HIGH STRENGTH DURALUMIN / HAIR LINE FINISH
- HORN SHAFT : HIGH STRENGTH DURALUMIN
- HANDLE LOCK SHAFT : MAIN · φ 20 HARD STAINLESS STEEL ALLOY
: SUB · φ 20 SUPER HARD ALLOY STEEL
- STEERING CUT PREVENTION PLATE : STEEL WITH BLACK PAINT
- INSTALLING RANGE :
HANDLE WHEEL THICKNESS : 10 PATTERNS / 39~125mm (SPONGE INCL.)
HANDLE SPOKE WIDTH (SPONGE INCL.): 4PATTERN (80/100/125/150mm)
- KEY CYLINDER : MADE FROM MAKELOCK ROTARY DISC CYLINDER (1 PC)
- KEY : 3 QTY (SPARE KEY INCL.) **NO DUPLICATION POSSIBLE**
- KEY PATTERN : 160,000,000 PATTERNS
- WEIGHT : 3.9kg
- HANDLE PROTECTION SHAFT COVER INCL.

| CODE | PRICE |
|-------------|---------|
| 881-1202000 | ¥45,000 |

HANDLE LOCK SHL-02 PREMIUM

K · TECT SECURITY LEVEL : **100**

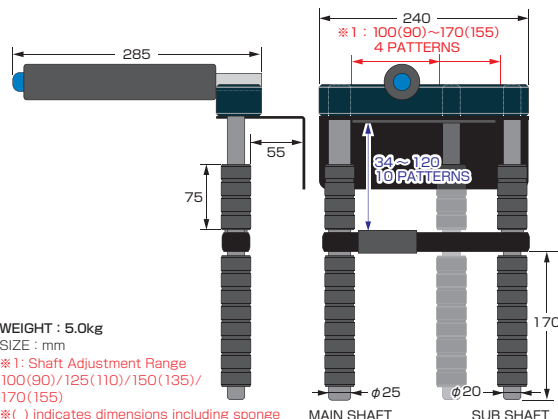

WEIGHT : 5.0kg
SIZE : mm
※ 1 : Shaft Adjustment Range
100 (90) / 125 (110) / 150 (135) /
170 (155)
※ () indicates dimensions including sponge

REMARKS

- UPPER BRACKET : HIGH STRENGTH DURALUMIN
TITANIUM COLOR ALUMITE FINISH
- UNDER BRACKET : HIGH STRENGTH DURALUMIN
BLACK ALUMITE FINISH
- HORN SHAFT : HIGH STRENGTH DURALUMIN
- HANDLE LOCK SHAFT : MAIN · φ 25 HARD STAINLESS STEEL ALLOY
: SUB · φ 20 SUPER HARD ALLOY STEEL
- STEERING CUT PREVENTION PLATE : STEEL WITH BLACK PAINT
- STEERING CUT PREVENTION PLATE SPONGE / GUARD PROTECTOR INCL.
- INSTALLING RANGE :
HANDLE WHEEL THICKNESS : 10 PATTERNS / 34 ~ 120mm (SPONGE INCL.)
HANDLE SPOKE WIDTH (SPONGE INCL.) : 4 PATTERNS (90/110/135/155mm)
- KEY CYLINDER : MADE FROM ABLOY SENTRY (1PC)
- 2 KEYS INCLUDED (SPARE KEY INCL.)
- KEY PATTERN : 360,000,000 PATTERNS
- SERIAL CARD : 1 QTY (FOR DUPLICATION)
- WEIGHT : 5.0kg
- HANDLE PROTECTION SHAFT COVER INCL.

| CODE | PRICE |
|-------------|---------|
| 881-1202010 | ¥63,000 |